

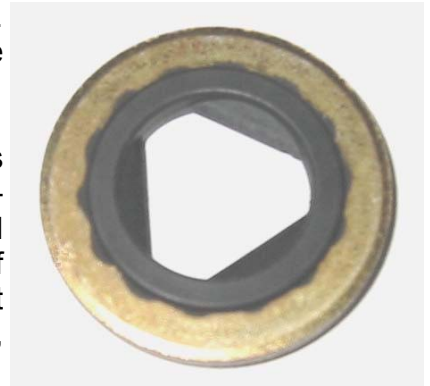

May 2007

Thread Seals

Roman Seals is proud to introduce the thread seal line of fastener seals. We have tooling on the most popular sizes and we are now introducing the TR-CN17-(size) line as a stock standard product.



Thread seals are reusable fastener seals designed to seal all leak paths on a threaded fastener. They are usually installed on the nut side of a fastener and create a seal against the nut, the mating hardware and the spiral leak path through the thread helix. One of the three wedges on the ID of the thread seal will always be in position to seal the V-shaped groove that forms the thread pattern on the fastener. Thread seals are self centering, easy to install and reusable if not damaged during installation.

Roman Seals PN	Reference PNs ^{Parker}	Rubber	Metal
TR-CN17-(size)	750-0002-(size)	Nitrile (NBR)	Zinc Plated Steel
TR-CN57-(size)	750-0000-(size) 7500-(size)	Nitrile (NBR)	Cadmium Plated Steel

The combinations listed above are just a sample of the materials available for thread seals. We have a wide variety of material combinations available to meet your specific application needs. Please call or e-mail us for a quote on your particular sealing requirements.

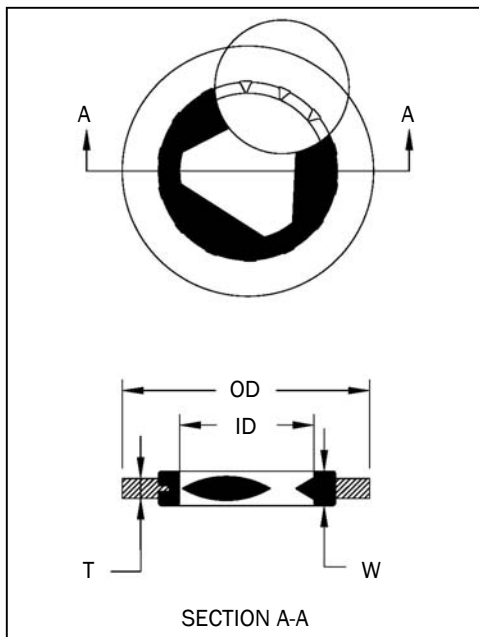

THREAD SEAL (size)	OD (+/- .010)	ID (+/- .010)	T (+/- .005)	W (+/- .005)
#6	.406	.141	.050	.078
#8	.406	.167	.050	.078
#10	.469	.194	.050	.086
1/4	.562	.255	.050	.092
5/16	.687	.319	.064	.107
3/8	.750	.383	.064	.113
1/2	1.000	.510	.078	.140
5/8	1.187	.638	.094	.165

All dimensions listed above are in inches. Sizes listed are sizes currently available from Roman Seals.

Please send your inquires via fax or e-mail, or call us for answers to all your sealing questions.

Roman Seals Corp. ♦ 17795 Sky Park Circle, Suite J ♦ Irvine, California 92614 ♦ USA

Phone: 949-450-1225 ♦ Phone: 888-766-2660 ♦ Fax: 949-450-1276

Web: www.romanseals.com ♦ E-mail: sales@romanseals.com